



LORRIC

Clamp-on Type Ultrasonic Flowmeters
FU-ES Series



QUICKCLAMP X EchoSense

FU-ES series



Chemical-resistance material



Convenient double screen design



Flexible Orientation

For 1/2 - 1 1/4 inch pipe size

(FU-ES015 / FU-ES020 / FU-ES025 / FU-ES032)

For 1 1/2 - 3 inch pipe size

(FU-ES040 / FU-ES050 / FU-ES065 / FU-ES075)



QUICKCLAMP



Easy 3 step installation



Non-invasive, suitable for various application

EchoSense



Time and cost efficient without coupling gel



Finish all pipe settings in one click



Why choose Ultrasonic Flowmeter?



Non-invasive installation

- ✓ No pipe loss
- ✓ No leakage
- ✓ No downtime
- ✓ No pressure drop
- ✓ No contamination

EchoSense Technology Principle

Time-of-Flight (ToF) measures wave travel time to accurately determine distance or flow rate.

$$\text{Flow Rate} = \text{Cross-Sectional Area} \times \text{Flow Velocity}$$

Where flow velocity was obtained through the **Time of Flight method**
(Calculating time offset from **A to B** and **B to A**)

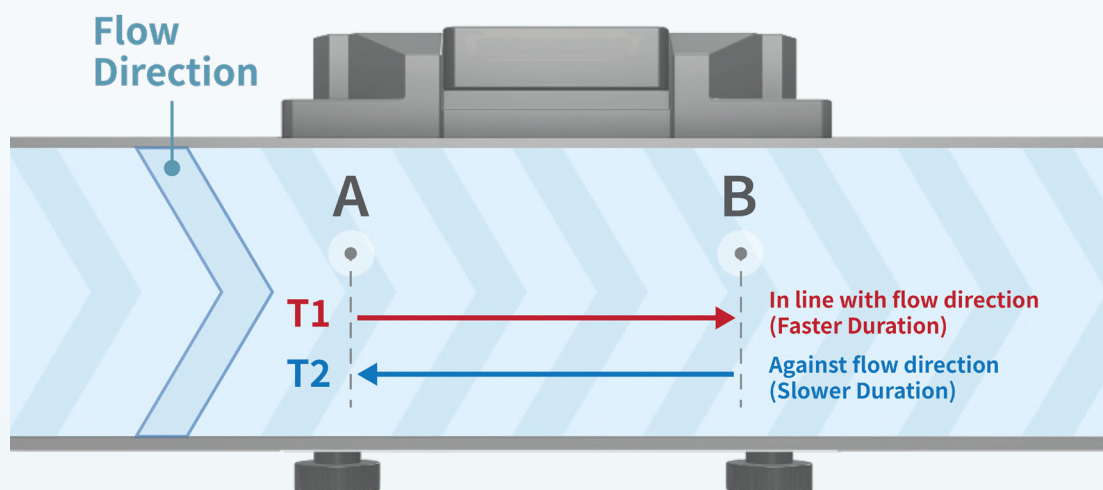

$$\text{Flow velocity} = \text{A to B and B to A time offset} \\ (T2 - T1)$$

Applicable to variety of fluids, pipe materials and diameters.

The EchoSense ultrasonic flow meter is highly versatile, capable of accurately measuring water, oil, and various chemicals. It is compatible with multiple piping materials, including stainless steel, PVC, PP, and PVDF, and supports different international pipe standards. Available in various models for pipe sizes from 1/2 to 3 EchoSense ensures stable and reliable performance across a wide range of industries.



<p>Applicable Fluids </p>	 <p>Water</p>	 <p>Oil</p>	 <p>Others (such as chemicals)</p>
<p>Pipe Materials</p>	 <p>Stainless Steel</p>	 <p>PVC</p>	 <p>Others (such as PP, PVDF, etc)</p>
<p>Pipe Specs</p>	 <p>1/2" ~ 3" For other pipe diameter needs, please contact us</p>		

EchoSense

No More Ultrasonic Gel, More efficient and cost saving operations

Traditional ultrasonic flowmeters rely on coupling gel to ensure proper signal transmission, but this method has several downsides—it's messy, costly, and time-consuming to apply. Over time, gel can degrade, dry out, or shift, leading to inaccurate measurements and the need for frequent reapplication.



LORRIC's ultrasonic flowmeter eliminates these hassles with an innovative gasket pad design. Instead of using gel, our flowmeter features a durable rubber gasket pad that ensures consistent and reliable signal transmission.

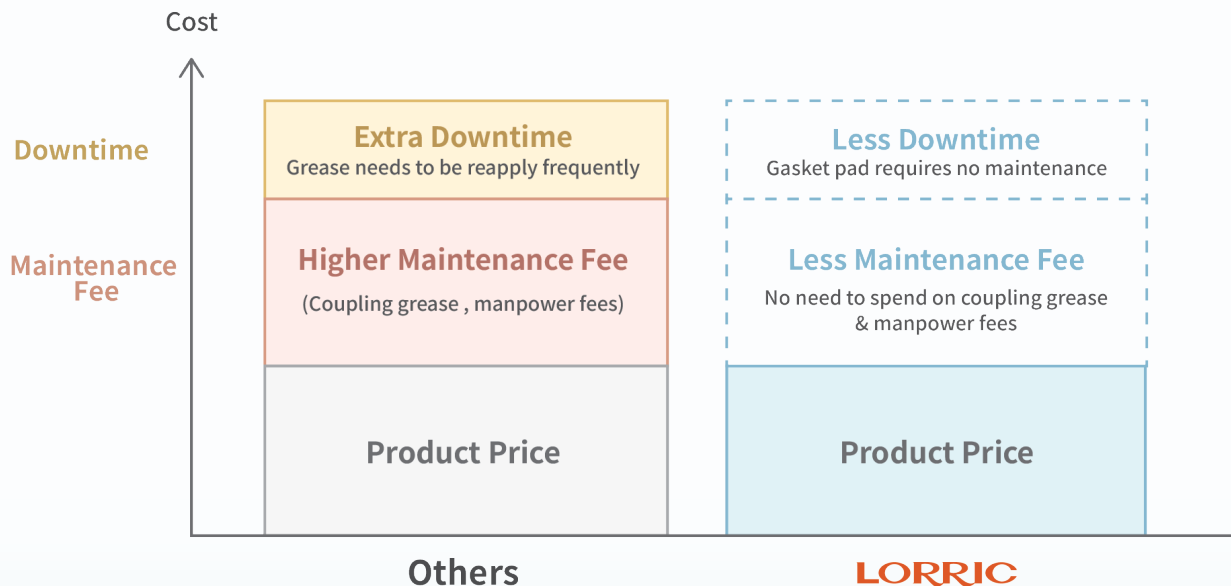

Complete all settings in 1 click with

Automatic Pipe Specification Matching

Traditional ultrasonic flowmeters often require manual input for details like pipe diameter and wall thickness, making setup time-consuming and prone to errors. LORRIC's EchoSense technology simplify this process with its built-in database of common pipe specifications, including PVC, PP, PVDF, and stainless steel.

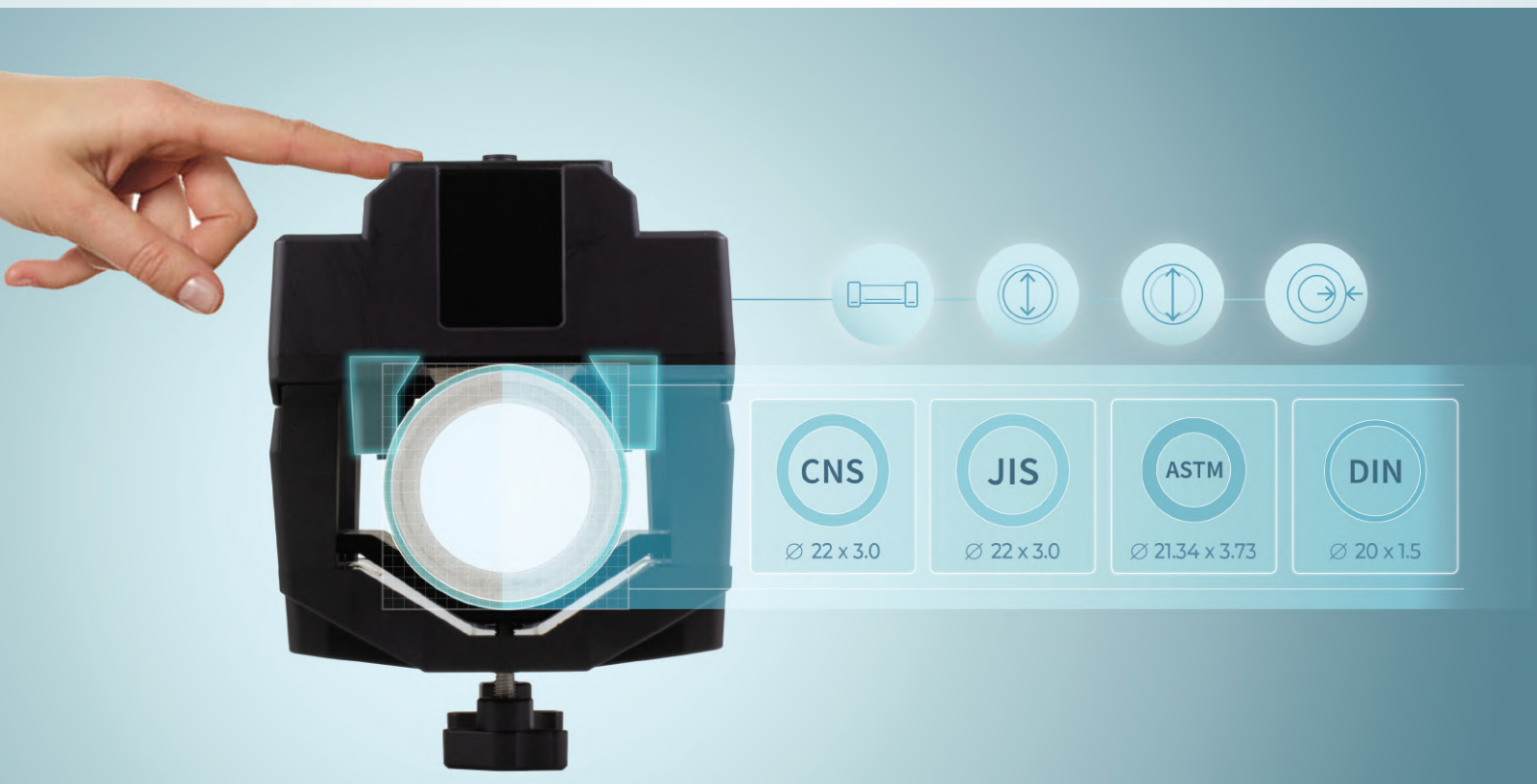

With just one click, it automatically matches the pipe with its database, automatically configuring pipe material, outer & inner diameter, and wall thickness. Supporting global pipe standards, this innovation minimizes manual data entry errors, streamlines installation, and ensures effortless adaptation to international markets.

Detect problems instantly and intelligently with Automatic Environment Sensing

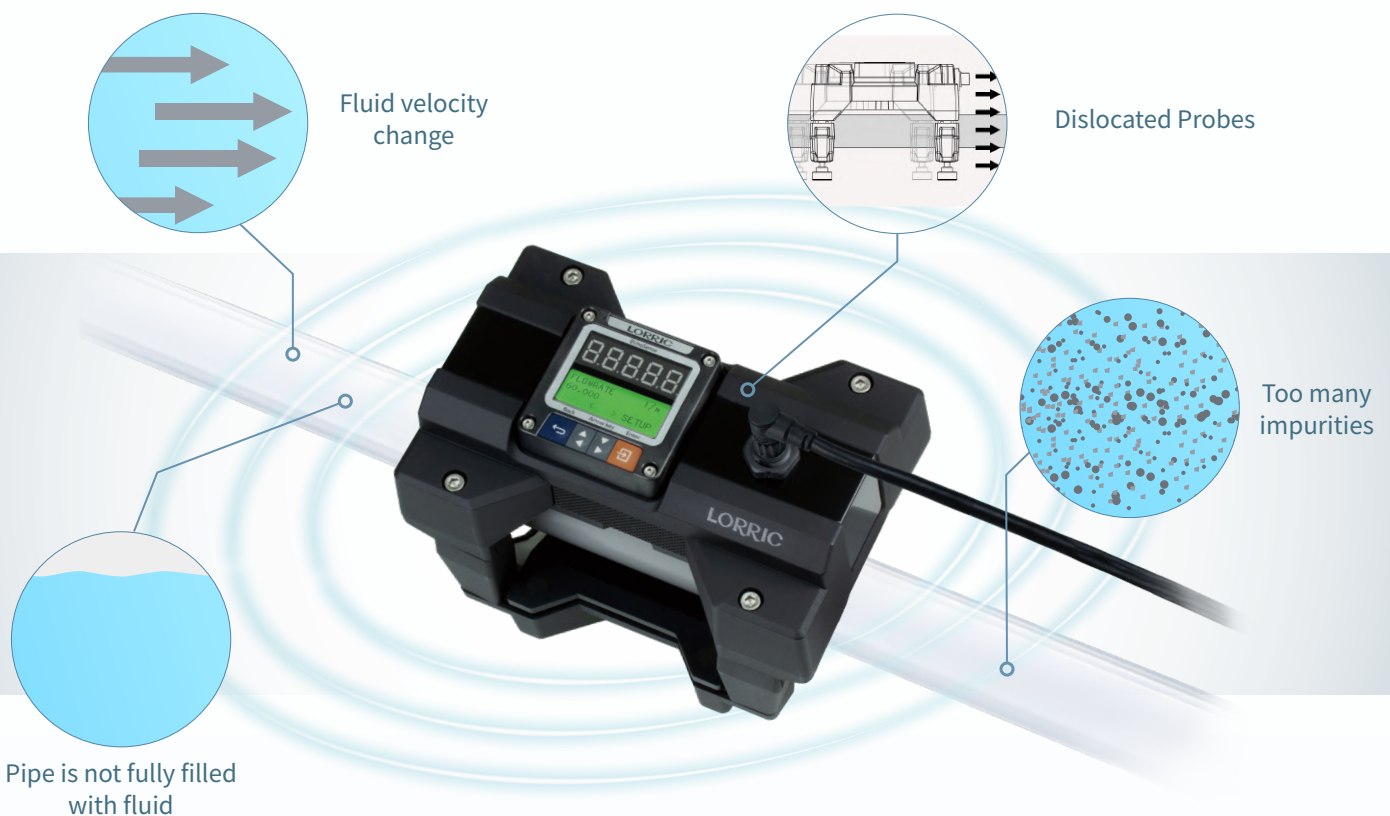

Our ultrasonic flowmeter takes precision to the next level with its third specialized transducer, designed exclusively for automatic environment sensing. This advanced feature continuously monitors critical variables, such as fluid sound velocity changes, incomplete pipe fills, or impurities in the flow. By detecting potential issues in real time, this technology minimizes downtime, prevents inaccurate readings, and keeps operations running smoothly. Experience smarter flow measurement with technology that adapts to your environment.

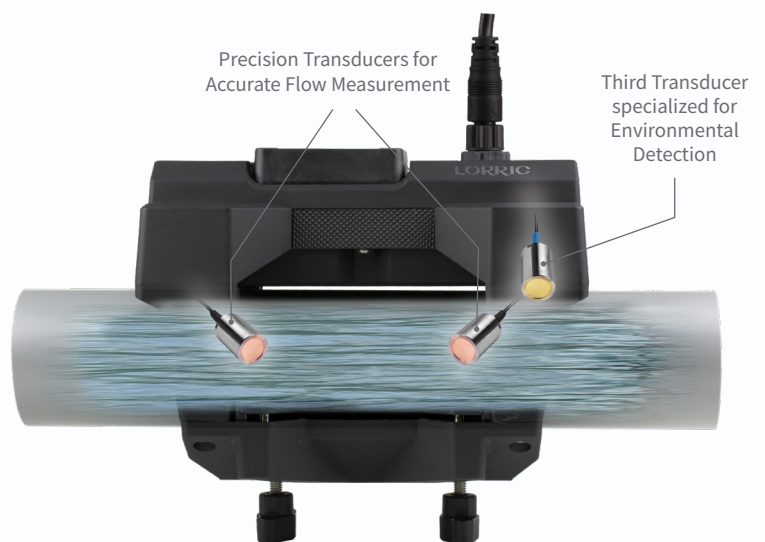

QUICKCLAMP

Compact Build, Seamless Installation

LORRIC's user-friendly design means fewer steps to set up than the rest. Just hold the compact main unit in one hand, secure it with a simple buckle using the other. It's a hassle-free experience, made simple for everyone.



Easy Installation with only

3

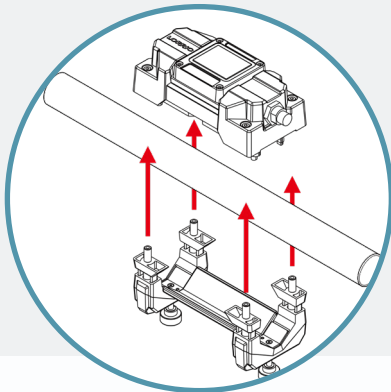
 Steps
in
Minutes

1. Mount

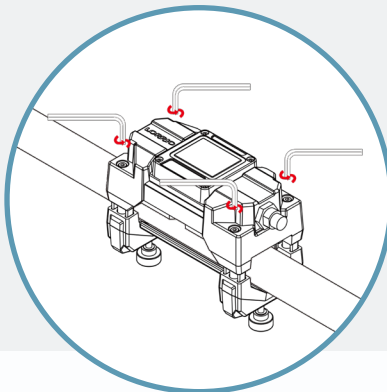

2. Lock

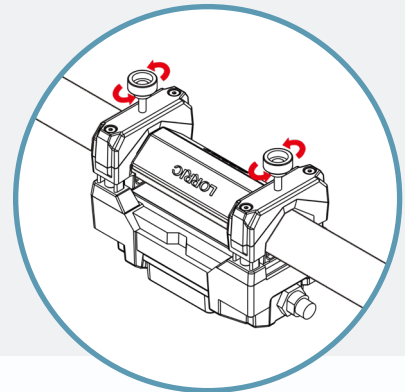

3. Tighten

Flexible Orientation for Every Pipeline



No matter your system's layout, our flowmeter adapts seamlessly. Designed for both vertical and horizontal installations, it ensures accurate performance and effortless integration into any pipeline configuration.

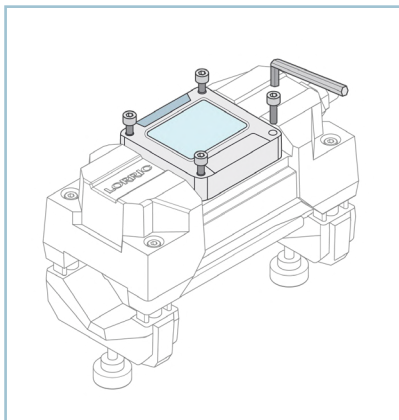

1. Unscrew the display panel to release it.

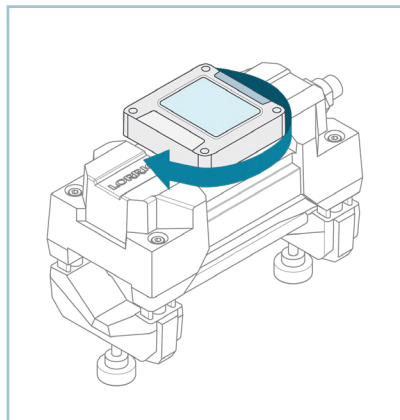

2. Rotate the screen to your desired orientation

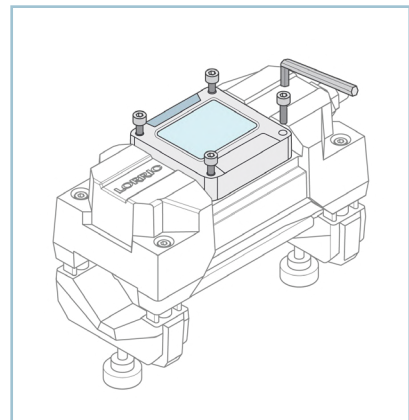

3. Reattach and tighten the screws securely to lock the screen in place

Instant Visual Feedback



LED

High-brightness large LED screen for easy long-distance flow number reading.

LCD

High-brightness large LCD screen for easy long-distance flow number reading.



GREEN

Normal Operation



RED

Error Detected



ORANGE

Setting Mode

FU-ES series

Usage Scenario

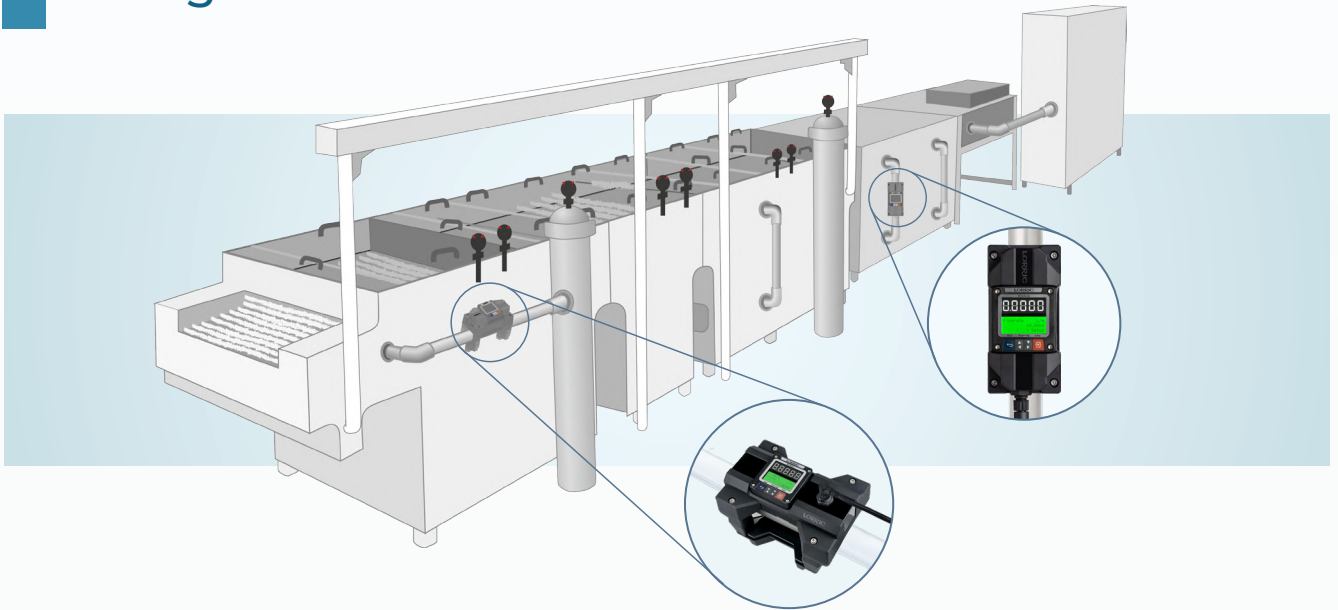

Harsh Chemical Environment

Ultrasonic flowmeters are perfect for chemicals due to their non-invasive design, which avoids direct contact with corrosive or hazardous fluids. Ensuring both accurate measurement and enhanced safety, protecting the fluid and your equipment.

To enhance chemical resistance, We integrate stainless steel 304 for internal structural support, while the outer casing is made of high-strength, chemically resistant industrial-grade leaded NYLON, PPS, and PEEK. This design ensures both durability and structural stability.



Ideal for Leased or Warrantied Equipment

FU-ES' s non-invasive installation requires no pipe cutting or modifications, preserving the integrity of leased equipment or machines under warranty. It allows precise flow measurement without risking warranty voidance or permanent changes.

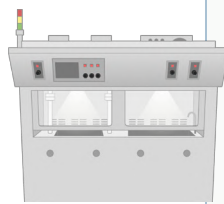

Prevent Wastage of Valuable Liquids

FU-ES ensures precise flow control for valuable liquids, minimizing wastage and maximizing efficiency. Its accurate real-time measurement helps protect precious resources and reduces unnecessary losses.



Replace Manual Flow Recording with Automated Accuracy



FU-ES eliminates the need for manual flow recording by automating the process. Its precision ensures continuous, accurate monitoring, reducing human error and boosting overall efficiency.

Maintain Purity for Easily Contaminated Liquids

FU-ES' s non-invasive design prevents contamination from external materials, keeping sensitive liquids pure. It ensures accurate flow measurement while maintaining fluid integrity in critical applications.

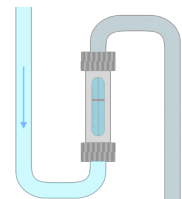

Award-Winning Excellence in Flow Measurement



LORRIC' s Ultrasonic Flowmeter has been recognized with two prestigious global awards:



iF Design Award 2024

iF Design Award, a global symbol of design excellence since 1953, honored the FU-ES in 2024 for its innovation, functionality, and user experience. With its innovative "QUICK CLAMP" design, FU-ES simplifies installation and setup challenges, providing a more efficient solution for industrial fluid monitoring.



Taiwan Excellence Award 2025

Taiwan Excellence Award, organized by TAITRA, recognizes outstanding R&D, design, and quality, with a strong focus on ESG sustainability. FU-ES earned this honor for solving flow measurement challenges in complex piping. "EchoSense" technology automatically adapts to various systems and fluids, reducing waste and optimizing resource use.

With award-winning technology in your hands, experience the next level of smart, precise, and efficient flow monitoring with LORRIC.

Product Specifications

















Installation method	Outside the pipe (clamp-on type)
Applicable pipe material	Metal pipe, Plastic pipe (UPVC/PPH/PVDF/PFA/PTFE)
Applicable fluid	Various liquids (no impurities or air bubbles)
Applicable fluid temperature	0~85°C (no ice on the piping surface)
Velocity range	±0.3 to 6.0 m/s recommended, ± 0.1 to 10m/s measurable
Language	English, Traditional and Simplified Chinese (others can be customized)
Units	Metric Meters, Cubic Meters, Liters Time - Seconds, Minutes, Hours, Days Imperial Feet, Cubic Feet, UK gallon, US gallon
Display mode	Dual screen display: 5-digit LED + 3-color backlight, 3-line 16-character LCD
Display update cycle	0.5s 1s
Display resolution*	±3.0% RD at 10% to 100% of F.S. ±0.3% F.S. at 0% to 10% of F.S.
Measurement Accuracy	Display resolution: maximum resolution 0.0001 (finest)
Power demand	DC 12V to 36V
Power I/O Connector	M12 8-pin connector
Input/Output	Analog output with self-powered 16-bit 4-20mA Modbus RTU RS485 Two-wire optocoupler switch signal (with 2 meters long signal line)
Consumption current	<200mA@12V when starting up and working stably (not included in the communication current)
Protection circuit	Power reverse connection protection, power surge protection
Waterproof level	IP66 **
Ambient temperature	-10~60°C (no freezing)
Relative humidity	[35~85%RH (non-condensing)]
Material	PPS+GF PEEK\NBR\Silicon\PA66+GF\PC+GF\SS304\PMMA

* The measurement accuracy is established in a controlled laboratory environment where the pipe and fluid conditions are set and the instrument is calibrated to zero before conducting tests at 25°C. Although statistical results are obtained under these conditions, there may be variances in accuracy when used in customer environments.

** Incorrect installation when rotating the screen by loosening the screws around it may affect the IP66 waterproof protection.

FU-ES series

Product List

	Model	Pipe diameter	Pipe outer diameter range	Recommended flowrate measurement range (May be inconsistent with different pipelines and liquids)	Weight (g)
	FU-ES015	1/2" dn15	20–22 mm 0.79–0.87 inch	1.5–120 LPM 0.4–31.7 gpm 	770
	FU-ES020	3/4" dn20	25–27.2 mm 0.98–1.07 inch	2–200 LPM 0.53–52.83 gpm 	770
	FU-ES025	1" dn25	32–34 mm 1.26–1.34 inch	3–300 LPM 0.79–79.25 gpm 	785
	FU-ES032	1-1/4" dn32	38–42.16 mm 1.5–1.66 inch	5–470 LPM 1.32–124.16 gpm 	800
	FU-ES040	1-1/2" dn40	48–50 mm 1.89–1.97 inch	8–770 LPM 2.11–203.41 gpm 	1390
	FU-ES050	2" dn50	60–63 mm 2.36–2.48 inch	13–1320 LPM 3.43–348.71 gpm 	1540
	FU-ES065	2-1/2" dn65	73–76.3 mm 2.87–3 inch	22–1670 LPM 5.81–441.17 gpm 	1580
	FU-ES075	3" dn75	88.9–90 mm 3.5–3.54 inch	30–1870 LPM 7.93–494 gpm 	1650

FU-ES series

Product Dimensions

FU-ES015 / FU-ES020 / FU-ES025 / FU-ES032

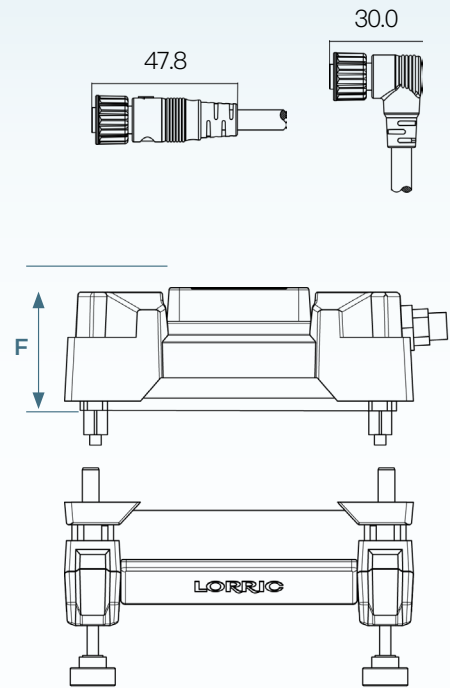
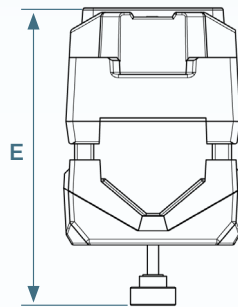
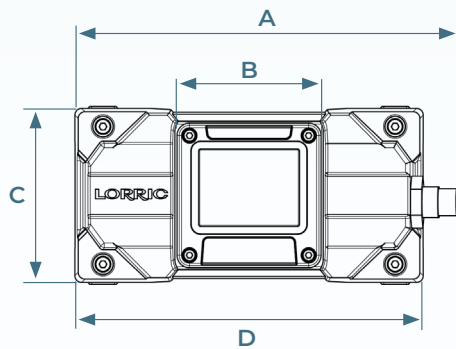

Unit: mm

	A	B	C	D	E	F
FU-ES015 (1/2" / dn15)	169.85	64	79	115	120.53	54
FU-ES020 (3/4" / dn20)	169.85	64	79	115	124.02	54
FU-ES025 (1" / dn25)	169.85	64	79	115	133.52	54
FU-ES032 (1 1/4" / dn32)	169.85	64	79	115	143.02	54

FU-ES040 / FU-ES050 / FU-ES065 / FU-ES075

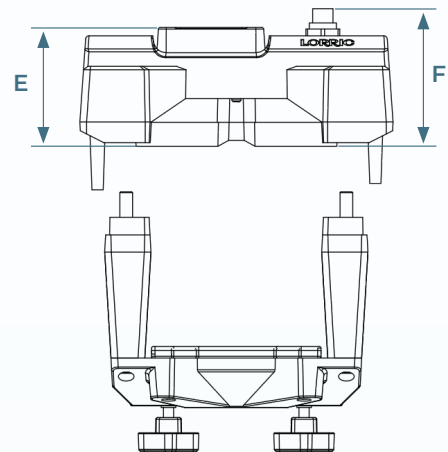
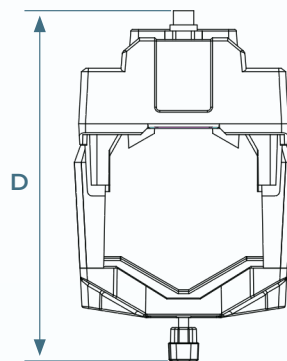
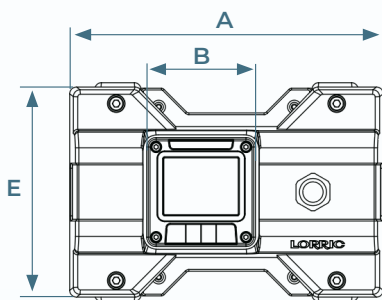

Unit: mm

	A	B	C	D	E	F
FU-ES040 (1 1/2" / dn40)	184.90	64	125.22	164.12	53.50	69.50
FU-ES050 (2" / dn50)	184.90	64	125.30	178.12	53.50	69.50
FU-ES065 (2 1/2" / dn65)	184.90	64	126.87	193.12	53.50	69.50
FU-ES075 (3" / dn75)	184.90	64	128.55	207.12	53.50	69.50

How to Order

Please follow the steps below to place your order:

1. Choose the suitable pipe size diameter and use the corresponding code
2. Choose the suitable connector cable type and use the corresponding code
3. Combine both order codes when placing your order
(Example: For a 40 mm pipe with a straight connector cable, your order code will be FU-ES020S)

1

Please choose:

Pipe Diameter

2

**Connector
Cable head**

Order code
example :

FU-ES025

R

Code :

FU-ES015	DN (mm) 15 DN (inch) 1/2
FU-ES020	DN (mm) 20 DN (inch) 3/4
FU-ES025	DN (mm) 25 DN (inch) 1
FU-ES032	DN (mm) 32 DN (inch) 1-1/4

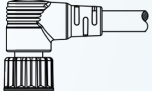

Code :

S	Straight 
R	90° angle 

FU-ES040	DN (mm) 40 DN (inch) 1-1/2
FU-ES050	DN (mm) 50 DN (inch) 2
FU-ES065	DN (mm) 65 DN (inch) 2-1/2
FU-ES075	DN (mm) 75 DN (inch) 3



FU-ES series

Installation Precautions

Extremely important precautions to take note before installing!!

If any of the scenarios below occur and cause damage to the flowmeter, the warranty is void.

1. If the device material is PC then it is not highly resistant to PVC glue which is a strong gas and lubricant for PVC pipe. Therefore, before installing the flowmeter you must ensure that the glue is dry between the connecting pipe and adapter.
2. Please pay special attention to the vertical flow of solvents and chemicals outside the pipeline since it may potentially cause damage to the flowmeter
3. Do not use this device as a support point for pipelines or other objects, which will cause the flowmeter to withstand external forces which it is not designed for, thus, shortening the usage life of the product or damaging it.
4. During the installation process, it's crucial to tighten the union nuts only by hand until the flowmeter does not move and rotate. Do not use iron pliers or other tools to avoid damage to the flowmeter.
5. The flowmeter is not permanently fixed to the outside of the pipeline, and can still move and rotate under excessive external force. Please do not use the flowmeter as a structure for personnel fixing, moving and safety protection.
6. The electronic device of the flowmeter is not UV resistant. Therefore, we suggest covering it with a protector if installed outdoors.
7. The seller will not be responsible for free maintenance for any defect or malfunction incurred by improper use and human errors.
8. If the flowmeter is transported with its piping system to another site without protection then it could be damaged.

How to Choose an Installation Location

The 1st principle for choosing an installation location is wherein the pipe is filled completely with liquid to avoid issues caused by air bubbles or precipitation in the pipe. The 2nd principle is allowing the flow in the pipe to be fully developed by having enough length on both sides of the straight pipe. This means no equipment should be left on either side like adaptors, elbow pipe, valves or pumps.

The LCD display screen should not be exposed to direct sunlight that could cause visibility issues and a shorter life usage. Therefore, installing the flowmeter under direct sunlight should be avoided or with a sunlight protector is recommended.

Vertical pipe

Please choose the vertical pipe with a bottom-up flow direction.

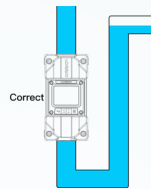

Horizontal pipe

Please choose the location with full liquid, like the lower part of the inclined pipe.

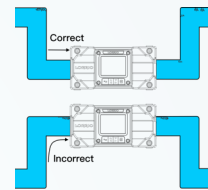

LORRIC's EchoSense flow meter should not be installed at the top right or bottom side of the pipe in order to avoid the interruption of air bubbles or precipitation.

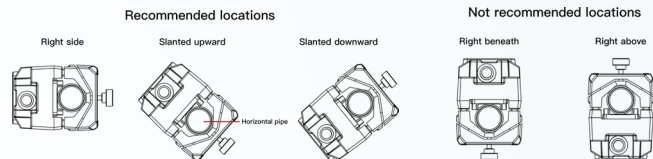

Please be cautious of the air bubble in the pipe to avoid measurement error.

If the installation location for the flowmeter is close to a tank where pressure is low. We recommend installing a valve at the pipe exit to avoid generating any air bubbles.

If air bubbles are frequently generated in the pipe, it may lead to a large non-reproducible measurement error which should be avoided.

New Product Installation Process

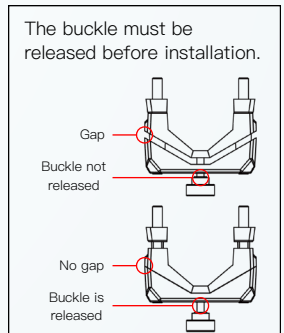
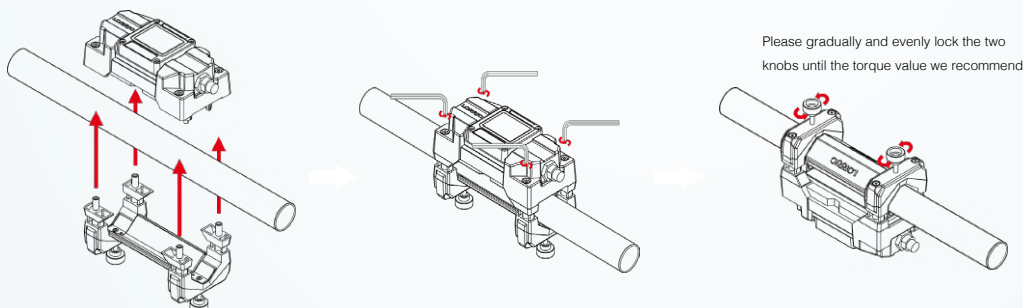

1. Make sure that the buckle is in the released position.
 2. After the device faces the intended operation direction, pre-lock the device and the buckle on both sides of the pipeline with screws. At this time, if it is a large pipe in the applicable pipeline, the device may not move. If it is a small pipe in the applicable pipeline and the device is still in a movable state, please lock the flowmeter.
 3. Tighten the two knobs on the fastener by hand, as long as the device does not rotate and move.
 4. Finished.
- *The torque value of the knob should be between 0.20 N-m (2kgf-cm) and 0.35 N-m (3.5kgf-cm), and should not exceed 0.4 N-m (4.0kgf-cm), which will damage or shorten the life of the flowmeter.



LORRIC

United Benefit Corp

8F, No.3, Lane 83, Sec. 1, Guangfu Rd.
Sanchong Dist. New Taipei City

TEL: +886-2-8511-2135
FAX: +886-2-8511-2097
E-mail: sales@lorric.com

www.lorric.com



FU-ES Website



FU-ES Instruction Manual