



Paddlewheel Flow Meter
FP-AS Series
FP-AS310



With Patented

AxleSense[™]
Technology

FP-AS310

Patented AxleSense Paddlewheel Flow Meter



Premium pipe fitting

Flexible Device installment:
Vertical/Horizontal

Highly Visible
Situational Backlight

Modular 3 piece design : Easier maintenance

Axlesense technology:
High accuracy measurement

Selectable Flow Direction Detection



Fluid Measurement Made Simple with Paddle Wheel Flowmeters

For industries that rely on precise fluid measurement such as water management, chemical processing, and agriculture, paddle wheel flowmeters have been a trusted solution for decades. Known for their practicality and reliability, paddle wheel flowmeters deliver accurate results without the complexity or high costs of advanced systems.

Challenges of Traditional Designs

While effective, traditional paddle wheel flowmeters face issues like paddle wear, installation sensitivities, and limited detection capabilities, which can affect long-term reliability, accuracy and efficiency.

Working Principle

A paddle wheel inside the pipe spins as fluid flows past it. Sensors track the rotation speed of the paddle wheel and translate this motion into accurate readings. It's a practical and proven method for flow measurement.

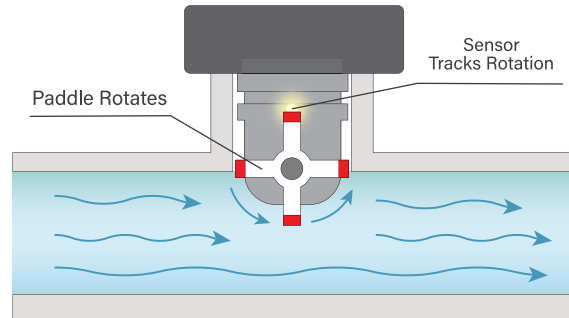

Reinventing Paddle Wheel Flowmeters: Precision Perfected with LORRIC's AxleSense



AxleSense technology revolutionizes signal measurement, significantly increasing signal output frequency for more accurate flow measurement.

Others

vs

LORRIC

Conventional paddle wheels have 4 blades ; signals are generated only when **magnets on the blades** pass the sensor.

generate one signal **per blade pass (90°)**

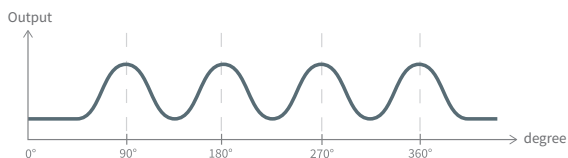
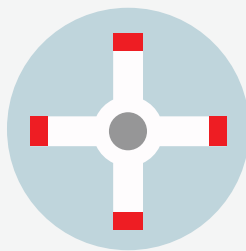

Standard Four-Blade Flow Meters Output
One Signal per 90 Degrees Rotation
Generally 1 to 2 Outputs per Revolution (max 4)

AxleSense Technology with **magnet on the axle**; signals are generated by measuring magnetic axle rotation. generate one signal **every 3°**

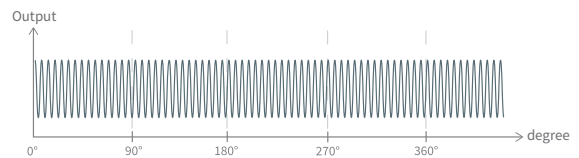
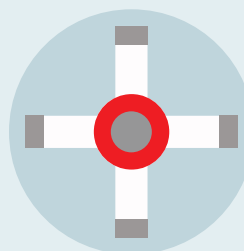

LORRIC AxleSense Flow Meters Output
One Signal Every 3 Degrees
120 Outputs per Revolution

Selectable Flow Direction Detection

Accurately measure flow direction with a selectable positive flow display



AxleSense's patented technology enables bidirectional flow detection by measuring paddlewheel rotation direction, overcoming the limitations of traditional paddlewheel flowmeters that use Hall effect sensors, which can detect rotation but not direction.

In the FP-AS310, this innovative feature provides essential directional flow data with a selectable positive flow display, enhancing measurement accuracy and operational control.



Traditional Paddle Wheel Flowmeter

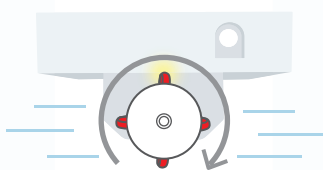

Detects flow by sensing the magnet on the paddles, without recognizing flow direction.

LORRIC's AxleSense

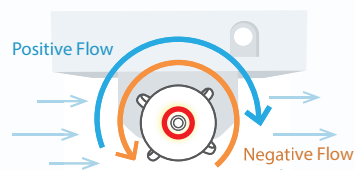

Detects both flow and direction by sensing the magnet rotation on the axle

Wider Detection Range

High accuracy measurement across low and high flow rates, boosting efficiency and minimizing errors in diverse applications.



High flow rate



Low flow rate

Double the Range, Outperforming Standard Flowmeters

Traditional paddlewheel flow meters often have significant errors or cannot detect flow at low flow rates in the fluid inside the pipe. Upgrade your flow measurement capabilities with LORRIC's AxleSense technology! No more worries about inaccurate readings or missed low flow rates. Our advanced innovation ensures enhanced accuracy and a broader measurement range, spanning from 0.15 m/s to 10 m/s — double that of competing brands.



* The FP-AS310 covers a measurement range of 0.3 m/s to 10 m/s. For measurements starting from 0.15 m/s, select the FP-AS510.

Real Time Smart Paddle Detection

Unexpected flow disruptions can impact your entire operation, but LORRIC's Real-Time Smart Detection keeps you one step ahead. By continuously monitoring the paddlewheel's condition, including magnet strength, wear, and damage, it ensures accurate readings and sends immediate alerts when issues arise. This minimizes downtime, prevents costly errors, and boosts operational efficiency. Ideal for critical industries, it seamlessly integrates with factory systems in Industry 4.0 environments, enabling smarter and more efficient management.



More details on
AxleSense online Manual:
Parameter List > H System
> H05

*Usage Note: The abnormality warning function helps on-site staff quickly identify equipment abnormalities. However, it may be affected by environmental factors, nearby equipment, or magnetic interference, reducing its effectiveness. Do not rely on this feature as your sole source for critical or safety-related alerts. For detailed troubleshooting or further assistance, please contact LORRIC for additional support

Instant Visual Feedback

LCD screen for easy flow and equipment status monitoring



LCD

LCD screen backlight with three-color warning light signal for visual monitoring of flow meter's normal and abnormal conditions.

GREEN



RED



ORANGE

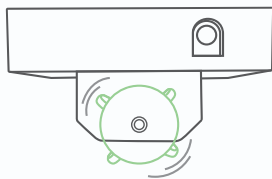

Normal Operation

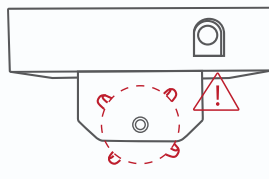

Error Detected

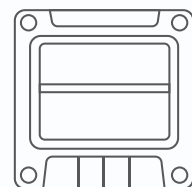

Setting Mode

Flexible Installation Options

Designed for both vertical and horizontal mounting, making installation simple and versatile.

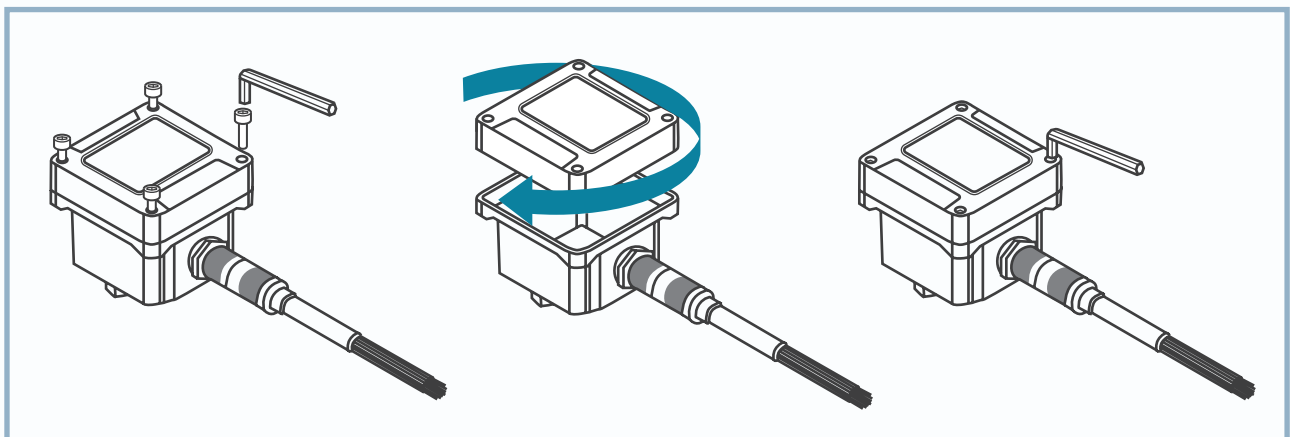

1. Unscrew the display panel to release it.

2. Rotate the screen to your desired orientation

3. Reattach and tighten the screws securely to lock the screen in place

Easy Maintenance with **LORRIC's Modular 3-Piece Design**

LORRIC's paddlewheel flowmeter features an innovative 3-piece design that simplifies maintenance and reduces costs. The system consists of three main components: the main unit, paddlewheel base, and pipe fitting. This modular design means you don't need to replace the entire system when a part wears out—just swap the affected component, saving both time and money on re-piping.



Universal Compatibility for FP-AS Series



LORRIC offers two versatile main unit models, FP-AS510 and FP-AS310, which are compatible with the same paddlewheel base and pipe fitting. This compatibility ensures easy maintenance and flexibility, helping you optimize your operations without worrying about costly part replacements.

With LORRIC, enjoy seamless maintenance, minimized downtime, and cost-efficient flow monitoring for the long haul, all in one.

Why Pipe Fitting Quality Matters in Flow Measurement

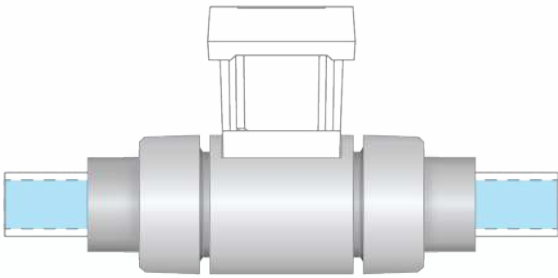

Pipe fittings are more than just connectors — they play a critical role in maintaining accurate flow measurement. Poorly manufactured fittings, especially those with uneven surfaces or imperfections, can disrupt the fluid flow, leading to turbulence, pressure drops, and inaccurate readings. Over time, these issues can compromise system efficiency and increase maintenance costs.

LORRIC's Premium Pipe Fittings: Engineered for Precision and Durability

Other Brands

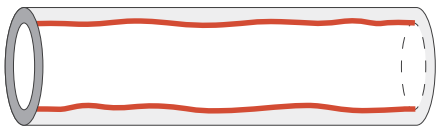

Wavy, inconsistent pipe fitting wall surface

Traditional plastic injection molding methods often produce fittings with uneven surfaces and inconsistent pipe walls, leading to unstable fluid flow and inaccurate readings. These issues, such as shrinkage, flash, and weak welds, can reduce the lifespan of fittings and compromise performance.

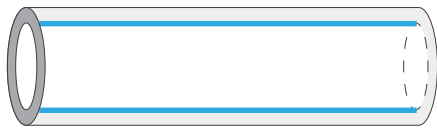
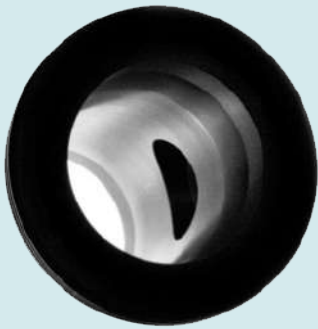

Flawless, smooth inner pipe fitting wall surface

At LORRIC, we've redefined pipe fitting quality with our premium manufacturing process. Instead of relying on conventional plastic injection molding, our fittings are crafted from extruded rod material. This method ensures a flawless, smooth inner surface that promotes stable fluid flow and enhances measurement precision.

When you choose LORRIC, you're not just selecting a fitting — you're investing in better performance, reduced downtime, and peace of mind. Our commitment to precision delivers the quality your system deserves.

Versatile Pipe Fittings for Every Industry: Choose the Right Material for Your Application

LORRIC's paddle wheel flowmeters are designed to provide flexibility and durability with pipe fittings made from a variety of materials, each carefully selected to meet the specific needs of different industries. Whether you're handling water, chemicals, or high-pressure systems, we have the right solution for you.



Specifications

Installation method	in-line (Pipe segment)
T-connector adapter	UPVC/PPH / PVDF (Made to order) / 316L Stainless Steel
Paddle material	PVDF or PPH with embedded magnet + ceramic bearing and shaft
Applicable fluid	Various liquids, impurities (<1%)
Applicable fluid maximum dynamic viscosity	300cSt *
Fluid in pipes temperature **	UPVC 0~50°C (32~122°F) / PPH : 0~90°C/PVDF: -15~100°C / ss316L : -20~100°C
Device working environment temperature	-10~60°C (14~140°F)
Flow velocity range	± 0.3~10m/s ***
Language	English, Traditional Chinese
Unit	Flow: L, m ³ , ft ³ , US gal Time: minute, hour
Display	16x3 3-Color Backlight LCD display
Response time	≤0.5 to 1 s (matches display update rate)
Display resolution	Maximum resolution 0.01 (finest)
Measurement accuracy	±2.5% RD ****
Linearity	±0.5% FS (>0.3m/s)
Reproducibility	± 0.4%
Power I/O connector	Quick Release 6-pin connector
Input/Output	[FP-AS310A] Analog output with self-powered 10-bit 4-20mA, 2-wire optocoupler switch signal (NPN) [FP-AS310R] Modbus RTU RS485
Consumption current	DC 24V 200mA (Excluding Communication Current)
Protection circuit	Power reverse connection protection, Power surge protection
Waterproof level	IP66 *****
Transient data	Instantaneous flow volume
Cumulative data	Cumulative positive flow
Display digits	LCD 10 Digits (Not including sign and decimal point)
Operation button	4 Key touch buttons
Calendar function battery	2 meters long signal line

*This machine is calibrated with normal temperature water before leaving the factory. Fluids with different viscosity than water will cause inaccurate calibration values and may also change the minimum and maximum flow rates.

** The working temperature of each material is for reference only. Please select based on design experience for actual selection.

*** Minimum flow rate values vary slightly due to flow field factors of individual models.

**** The measurement accuracy is based on the statistical results of the laboratory tests with room temperature 25 degrees C and clean water. Errors may occur due to the customer's usage environment.

***** The IP of IP66 is the abbreviation of Ingress Protection. The IP level is the protection level of the electrical equipment shell against foreign matter intrusion. The format of the IP level is IPXX, where XX is two Arabic numerals, and the first marked number indicates contact protection, and foreign object protection level, used to indicate dust resistance, the second marked number indicates the waterproof protection level, the larger the number, the better the protection level. The first 6 of IP66 means: completely prevent dust from entering; the second 6 means: no harm caused by high-pressure water splashing.

Explore FP-AS310 Configurations: Size, Flowrate, and Pipe Fitting Options

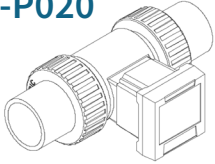
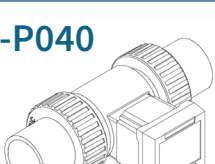
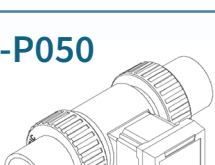
	Applicable Diameter	Flow Range	Fitting Material Options
FP-P015 	DN 15 (mm)	4-120.6 LPM	<ul style="list-style-type: none"> • UPVC • PPH • PVDF • Stainless Steel (316L)
	1/2" NPS	1.056-31.85 gpm	
FP-P020 	DN 20 (mm)	7-188.5 LPM	<ul style="list-style-type: none"> • UPVC • PPH • PVDF • Stainless Steel (316L)
	3/4" NPS	1.84-49.79 gpm	
FP-P025 	DN 25 (mm)	9-294.5 LPM (Stainless Steel: 7-294.5 LPM)	<ul style="list-style-type: none"> • UPVC • PPH • PVDF • Stainless Steel (316L)
	1" NPS	2.37-77.79 gpm (Stainless Steel: 1.8-77.79 gpm)	
FP-P032 	DN 32 (mm)	19-452.9 LPM	<ul style="list-style-type: none"> • UPVC • PPH • PVDF • Stainless Steel (316L)
	1¼" NPS	5.01-119.64 gpm	
FP-P040 	DN 40 (mm)	28-754.0 LPM	<ul style="list-style-type: none"> • UPVC • PPH • PVDF • Stainless Steel (316L)
	1½" NPS	7.39-190.36 gpm	
FP-P050 	DN 50 (mm)	50-1225.7 LPM	<ul style="list-style-type: none"> • UPVC • PPH • PVDF • Stainless Steel (316L)
	2" NPS	13.20-323.79 gpm	
FP-P065 	DN 65 (mm)	95-2179.0 LPM	<ul style="list-style-type: none"> • UPVC • PPH • PVDF
	2½" NPS	25.09-575.6 gpm	

Size | UPVC | PPH | PVDF

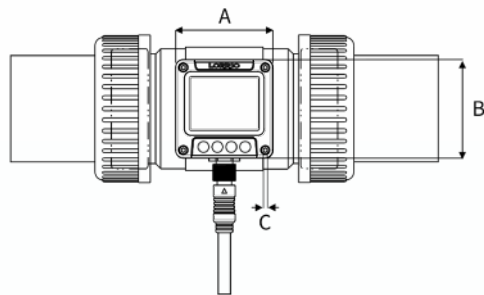

Unit: mm

Device Size		
A	B	C
63	63	2.5

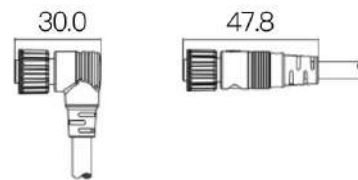
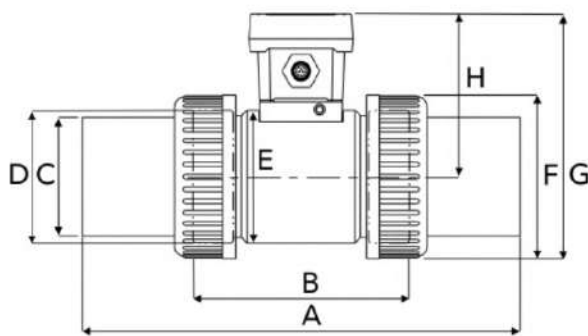

Unit: mm

Plastic pipe – union diameter size								
	A	B	C	D	E	F	G	H
1/2"	164	100	27.6	36	62.3	46.2	115.7	86.2
3/4"	168	100	32.6	41.9	62.3	50.5	115.7	85.7
1"	168	100	40.6	50	62.3	60	115.7	85.7
1 1/4"	210	114	50.2	59.6	65	75.6	127	89.2
1 1/2"	218	120	56	65.7	70	83	134	92.5
2"	269.5	133.3	72	81	81	99.7	148.8	99

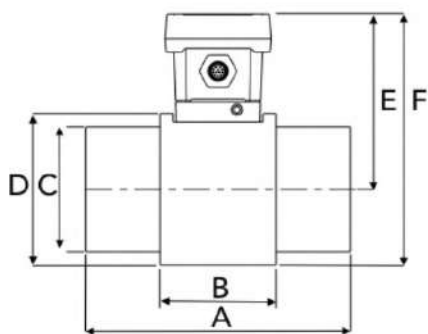

Unit: mm

Plastic pipe – spigot pipe diameter size						
	A	B	C	D	E	F
2 1/2"	160	70	76	92	106.5	152.5

Size | Stainless Steel

Metal Female Thread

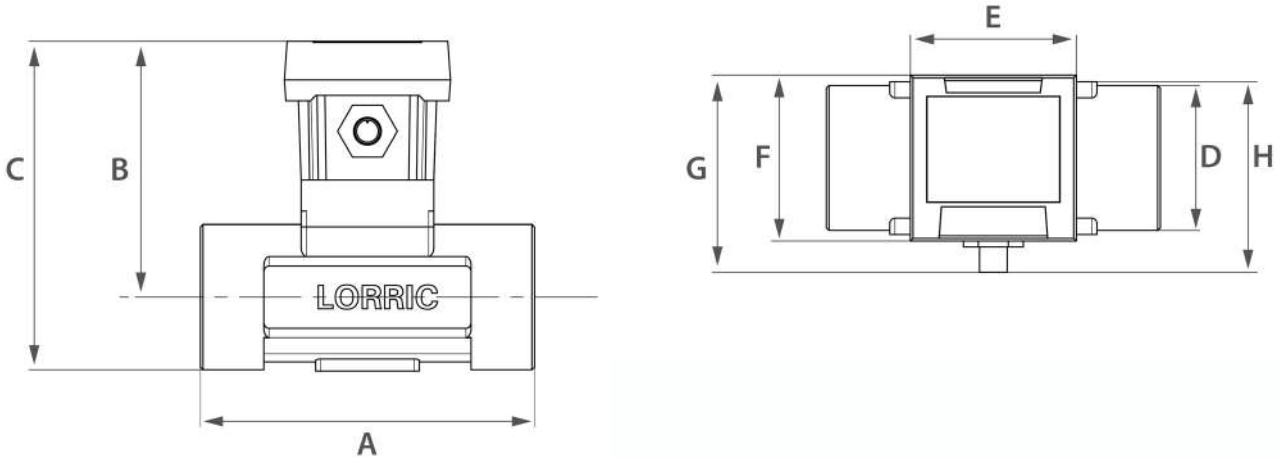

Stainless steel - Female Thread								
	A	B	C	D	E	F	G	H
1/2"	120	89.37	103.4	27	64.1	64.1	64.1	76.15
3/4"	120	89.5	106.91	-	64.1	64.1	64.1	76.15
1"	120	89.41	111.16	42	64.1	64.1	-	76.15
1 1/4"	119	95.2	120.7	51	64.1	64.1	51	76.15
1 1/2"	129	98.55	126.55	56	64.1	64.1	56	76.15
2"	148.5	104.98	137.98	65	64.1	64.1	76.15	78.12

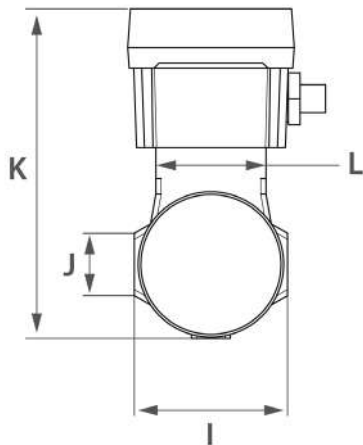

Stainless steel - Female Thread				
	I	J	K	L
1/2"	95.41	-	95.41	42.4
3/4"	42.4	-	106.91	42.4
1"	-	-	111.16	42.4
1 1/4"	54	20	121.2	42.4
1 1/2"	59	24	127.05	42.4
2"	68	30	137.98	42.4

Size | Stainless Steel

DN 25 1" Metal Male Thread

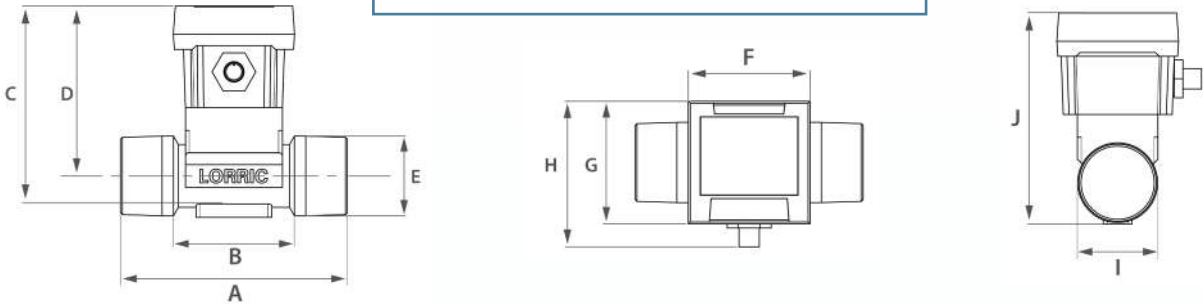

DN-25 (1") Stainless steel - Male Thread

	A	B	C	D	E	F	G	H	I	J
1/2"	120	58.8	111.16	89.41	33	64.1	64.1	76.15	42.4	111.16

DN 20 3/4" Metal Male Thread

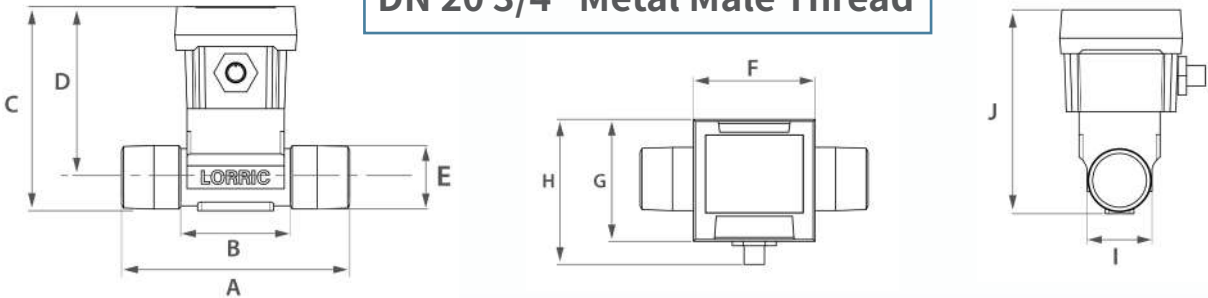

DN-20 (3/4") Stainless steel - Male Thread

	A	B	C	D	E	F	G	H	I	J
3/4"	120	57.69	106.09	89.4	30	64.1	64.1	76.15	42.4	106.09

DN 15 1/2" Metal Male Thread

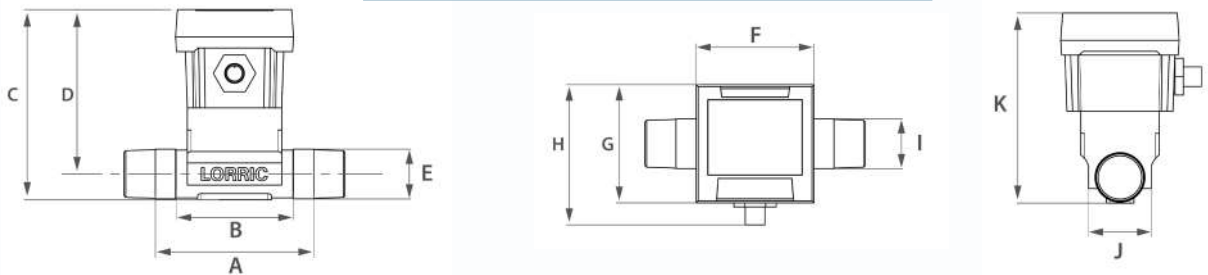

DN-15 (1/2") Stainless steel - Male Thread

	A	B	C	D	E	F	G	H	I	J
1"	120	63.42	103.41	89.41	26	64.1	64.1	76.15	34	103.41

How to Order

The whole set of paddle wheel flowmeter contains: Device, Paddle set, T-connector.

1. Select the flowmeter device and cable connector (Order code example: FP-AS310A(S))
2. Choose the T-connector + paddle set based on size, materials, type and pipe specification (Example: FP-P050CUAV)
3. For ordering the whole set, combine both codes altogether (Order code example: FP-AS310A(S) + FP-P050CUAV)

1 Please Choose: Device

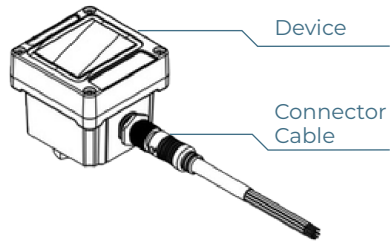

2 Please Choose: Connector Cable



Device

Connector Cable

Order Code Example: FP-AS310A (S)

<input type="checkbox"/> FP-AS310A	4-20mA and NPN	<input type="checkbox"/> (S)	Straight 
<input type="checkbox"/> FP-AS310R	RS485	<input type="checkbox"/> (R)	90° angle 

Union Fitting

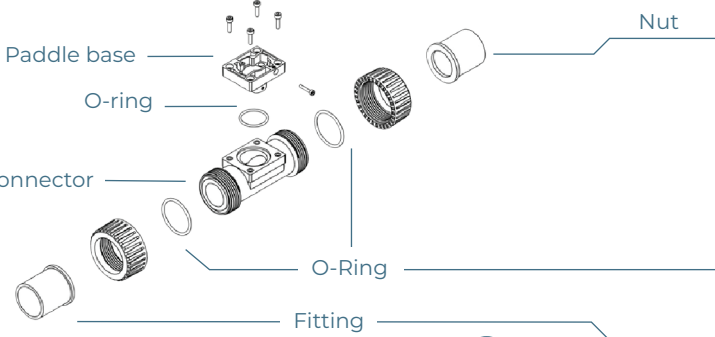

Paddle base

O-ring

T-connector

O-Ring

Fitting

Nut

3 Please Choose:

T-connector

Select pipe size:

Fitting Spec

Select fitting spec:

O-Ring Material

Select material:

Order Code Example: FP-P050

C

U

A





V

Code:

<input type="checkbox"/> FP-P015	1/2" Pipe
<input type="checkbox"/> FP-P020	3/4" Pipe
<input type="checkbox"/> FP-P025	1" Pipe
<input type="checkbox"/> FP-P032	1-1/4" Pipe
<input type="checkbox"/> FP-P040	1-1/2" Pipe
<input type="checkbox"/> FP-P050	2" Pipe

For 2-1/2" Pipe size, please refer to next page

Code:

<input checked="" type="checkbox"/> C	U-PVC	
<input type="checkbox"/> P	PPH	
<input type="checkbox"/> F	PVDF	
<input type="checkbox"/> S	Stainless Steel (316L)	

Code:

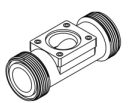
<input type="checkbox"/> U	Union + fitting	
----------------------------	-----------------	---

For Spigot & Flange fitting, Please refer to next page

Code:

(For U-PVC T-connector) :

<input checked="" type="checkbox"/> T	Taiwan CNS
<input checked="" type="checkbox"/> A	ANSI/ASTM
<input checked="" type="checkbox"/> N	GB
<input checked="" type="checkbox"/> J	JIS
<input checked="" type="checkbox"/> E	DIN
<input checked="" type="checkbox"/> F	BSPT Female Thread
<input checked="" type="checkbox"/> M	BSPT Male Thread
<input checked="" type="checkbox"/> R	NPT Female Thread
<input checked="" type="checkbox"/> Q	NPT Male Thread

(For PPH / PVDF T-connector) :

<input checked="" type="checkbox"/> 6	Insertion welding fitting (Default): ISO 15494 (PPH) ISO 10931 (PVDF)
<input checked="" type="checkbox"/> 5	Butt welding fitting (Made to order): ISO 15494 SDR11 (PPH) ISO 10931 SDR21 (PVDF)

(For Stainless Steel T-connector) :

<input type="checkbox"/> F	BSPT Female Thread
<input type="checkbox"/> M	BSPT Male Thread
<input type="checkbox"/> R	NPT Female Thread
<input type="checkbox"/> Q	NPT Male Thread

(For Stainless Steel T-connector) :

<input type="checkbox"/> T	Thread
----------------------------	--------

Code:

<input type="checkbox"/> E	EPDM
<input type="checkbox"/> V	VITON
<input type="checkbox"/> A	FEPM

* The common specifications are listed above, please contact our sales for delivery and inventory.

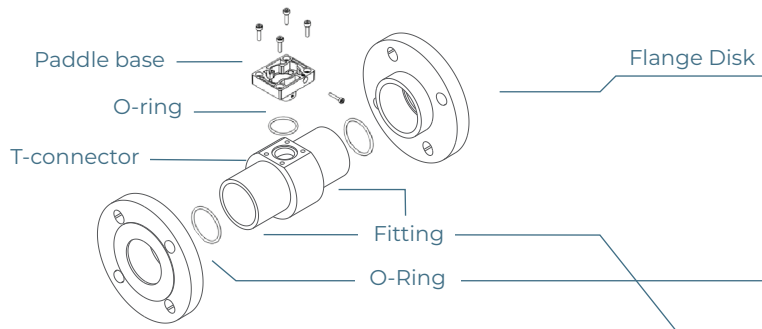

Spigot Fitting



Please Choose:

3	T-connector	4	Fitting Spec	5	O-Ring Material
Select pipe size:	Select pipe material:	Select T-connector fitting type:	Select fitting spec:	Select material:	

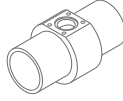
Order Code Example:	FP-P065	C	S	A	V
---------------------	---------	---	---	---	---

Code: ■ FP-P065 2-1/2" Pipe	Code: ■ C U-PVC 	Code: ■ S Spigot fitting 	Code: (For U-PVC T-connector) : ■ T Taiwan CNS ■ A ANSI/ASTM ■ N GB ■ J JIS ■ E DIN	Code: ■ E EPDM ■ V VITON ■ A FEPM
	■ P PPH 		(For PPH / PVDF T-connector) : ■ 6 Insertion welding fitting (Default): ISO 15494 (PPH) ISO 10931 (PVDF) ■ 5 Butt welding fitting (Made to order): ISO 15494 SDR11 (PPH) ISO 10931 SDR21 (PVDF)	
	■ F PVDF 			

Flange Fitting

(Available by custom order only)

Please Choose:

3	T-connector	4	Fitting Spec	5	O-Ring Material
Select pipe size:	Select pipe material:	Select T-connector fitting type:	Select fitting spec:	Select material:	

Order Code Example:	FP-P050	C	F	A	V
---------------------	---------	---	---	---	---

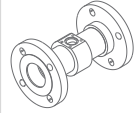
■ FP-P050 2" Pipe ■ FP-P065 2-1/2" Pipe Please contact our sales for other pipe sizes	■ U-PVC	■ F 	■ K JIS 10K TS	■ E EPDM ■ V VITON ■ A FEPM
---	---------	---	----------------	-----------------------------------

* The common specifications are listed above, please contact our sales for delivery and inventory.

LORRIC AxleSense Paddlewheel Flow Meter Series: AS510 vs. AS310

FP-AS510



FP-AS310



Complex conditions,
require more features

Suitable Scenarios

OEM customers,
large-scale installations,
price-sensitive applications



Double screen design
LED 5 Digits LCD 10 Digits

Screen Display

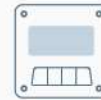

Single screen design
LCD 10 Digits

Positive flow
negative flow
net flow volume

Total Flow

Positive flow only

One version

For Analog output 4-20mA,
Modbus RTU RS485, 2-wire
photoelectric switch signal
(compatible with NPN/PNP)

Model Types

Two version

FP-AS310R for rs485
FP-AS310A for 4-20mA and
Switch Signal (NPN)

Flow speed 0.15~10m/s

Measurement Range

Flow measurement
above 0.3 m/s



M12 8-pin
DC 12V to 36V 100mA

Power Modes



Quick-release 6-pin
DC24V 100mA

Specification Comparison

	FP-AS510	FP-AS310R/FP-AS310A
Suitable Scenarios	Complex conditions, require more features	OEM customers, large-scale installations, price-sensitive applications
Device Material	PC + GF (glass fiber)	PC + GF (glass fiber)
Power Demand	DC 12V to 36V 100mA	DC24V 100mA
Fluid Temperature	0~50°C (32~122°F)	0~50°C (32~122°F)
Working Environment Temperature	-10~60°C (14~140°F)	-10~60°C (14~140°F)
Models Types	One version for Analog output 16bit 4-20mA, Modbus RTU RS485, 2-wire photoelectric switch signal (compatible with NPN/PNP)	Two versions FP-AS310R for RS485, FP-AS310A for 4-20mA, 2-wire photoelectric switch signal (compatible with NPN/PNP)
4-20mA Resolution	16-bit	10-bit
Power I/O Connector	M12 8-pin	Quick-release 6-pin
Data Accumulation Display	Cumulative flow: positive flow, negative flow, and net flow volume. Includes a 14-day historical flow record with timestamps.(past 14 days daily totalizer)	Cumulative flow: Positive Flow (Display only positive flow, direction selectable)
Transient Data	Instantaneous flow rate, instantaneous flow velocity	Instantaneous flow rate
Display Digits	LED 5 Digits LCD Maximum 9 digits	LCD Maximum 9 digits
Calendar Function Battery	CR2032 (For past 14 days totalizer only)	No battery
Bi-directional Flow Detection	Yes, show both positive and negative flow	No, flow direction can be changed but only positive will display
Volume and Time unit	Volume unit: L, m3, US Gallon, Imperial Gallon, ft3. Time Unit: seconds, minutes, hours, days.	Flow Units: m3, L, US gallons, ft3 Time Units: minutes, hours
Flow Velocity Unit	Unit of flow speed, default m/s. Metric: m/s Imperial: ft/s	N/A
Extension Mode	Set Low Flow Extension, Maximum Measurement Flow Range: 0.15~10m/s.	Set Low Flow Extension, Maximum Measurement Flow Range: 0.3~10m/s.
Pulse Width	0.5 ms (millisecond), 1ms, or 10ms. The default is 0.5ms.	1ms, or 10ms. The default is 1ms.
RS485 Baud	The Modbus communication baud rate can be set when the device is turned off to 9600, 19200, 38400, or 57600. The default setting is off.	The Modbus communication baud rate can be set when the device is turned off to 9600, 19200, or 38400. The default setting is off.
Iout Def. (Iout Definition)	4 options of the output data of Analog signal: off, flowrate, velocity and total.	The output data of the analog signal is the instantaneous flow rate.
Iout Range	2 options of analog signals: 4-20mA, 0-20mA Default is 4-20mA.	Only one analog signals: 4-20mA



LORRIC

United Benefit Corp

8F, No.3, Lane 83, Sec. 1, Guangfu Rd.
Sanzhong Dist. New Taipei City

TEL: +886-2-8511-2135
FAX: +886-2-8511-2097
E-mail: sales@lorric.com

www.lorric.com

2026-5



FP-AS310 Website



FP-AS310
Instruction Manual